

Material Datasheet

1300 Solid\Hollow LIGHTWEIGHT LiteCrete® Block

STANDARD FINISH

With LiteCrete® Block range of Dense and Lightweight Aggregate Blocks by **envicrete**, you are assured to find the building solution you need. Our blocks can be used with confidence in a wide variety of internal and external applications. Our quality assures that LiteCrete® Block units are of consistent and superior quality to meet the requirement of ASTM C-90.

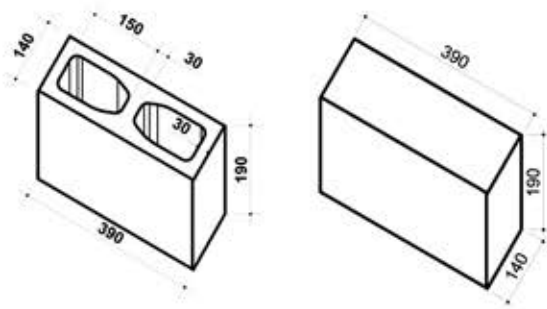

Size available Solid \ Hollow Block (in mm)

Length	Height	Width
390	190	140
Block Weights (kg)*	Weights (kg) Hollow Block	Weights (kg) Solid Block
Dry	7.5	13.2
3% Moisture Content	7.7	13.6

*These figures are a national average and variations may occur geographically, please contact your nearest Sale Office for more precise block weight.

Product Specifications

LiteCrete® Block TO ASTM C-90

'Aggregate Concrete Masonry Units Category 1 (dense and light-weight aggregates)'

CATEGORY:	AGGREGATE CONCRETE MASONRY UNIT
DIMENSIONAL TOLERANCES :	±3.5mm
COMPRESSIVE STRENGTH :	Mean 4.5 Mpa
REACTION TO FIRE :	Class A1 (3.5 hours)
WATER ABSORPTION :	18-20 lbs/cft
WATER VAPOUR PERMEABILITY :	NA
GROSS DRY DENSITY :	1300 kg/m ³
NET DRY DENSITY :	1300 kg/m ³
THERMAL CONDUCTIVITY :	0.5 W/mk
DURABILITY AGAINST FREEZE-THAW :	NA



Features and Benefits

- Designed to meet the requirements of the Building regulations
- Demonstrates a high level of performance in loadbearing and other structural applications
- Manufactured utilising lightweight aggregates for a lighter block
- Meets the requirements of the manual handling regulations
- Open textured finish provides an excellent medium for surface finishes and fixings
- Inherent light weight limits heat loss through external walls